

PROJECT REF:	
UNIT REF:	
FOOT PRESSURE:	
UDL:	

Material grade: BS EN 10219-1:2006 (S235JR). Welding standard: BS EN ISO 15614-1: 2016. Galvanizing standard: BS EN ISO 1461:2009
 Reference specification document "Custom Fabrication Specification" (BF-SPEC-050411) for further information
 Reference specification document "Big Foot Systems Steel Specification (BF-SPEC-230610) for further information

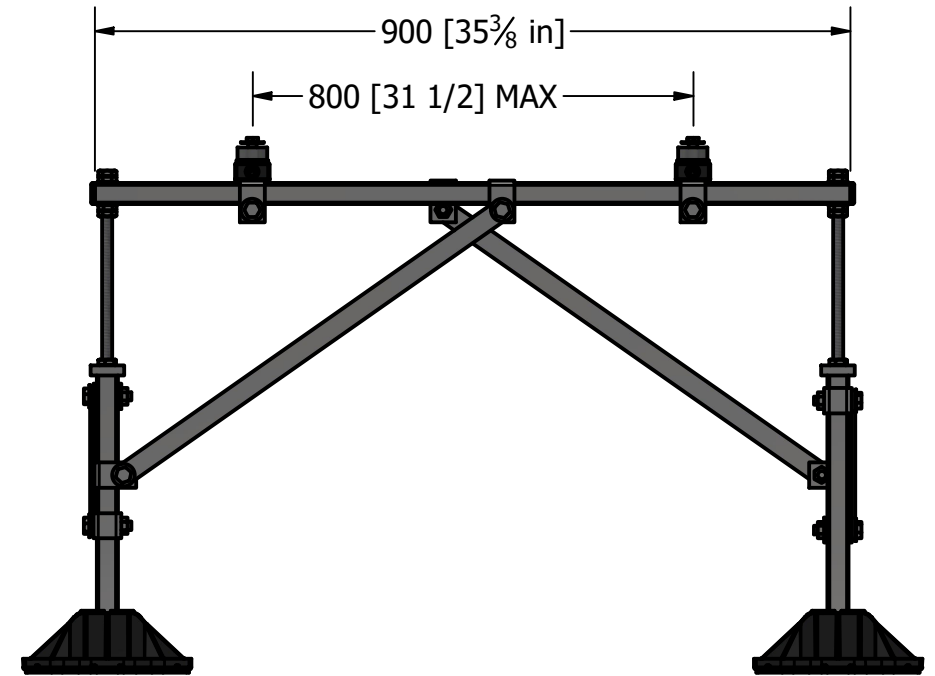
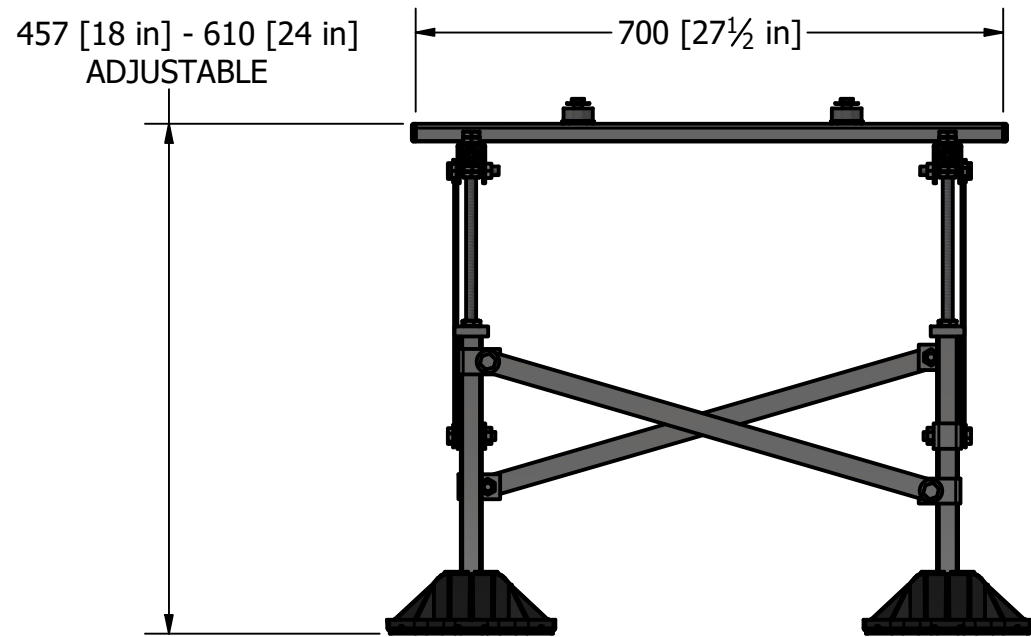
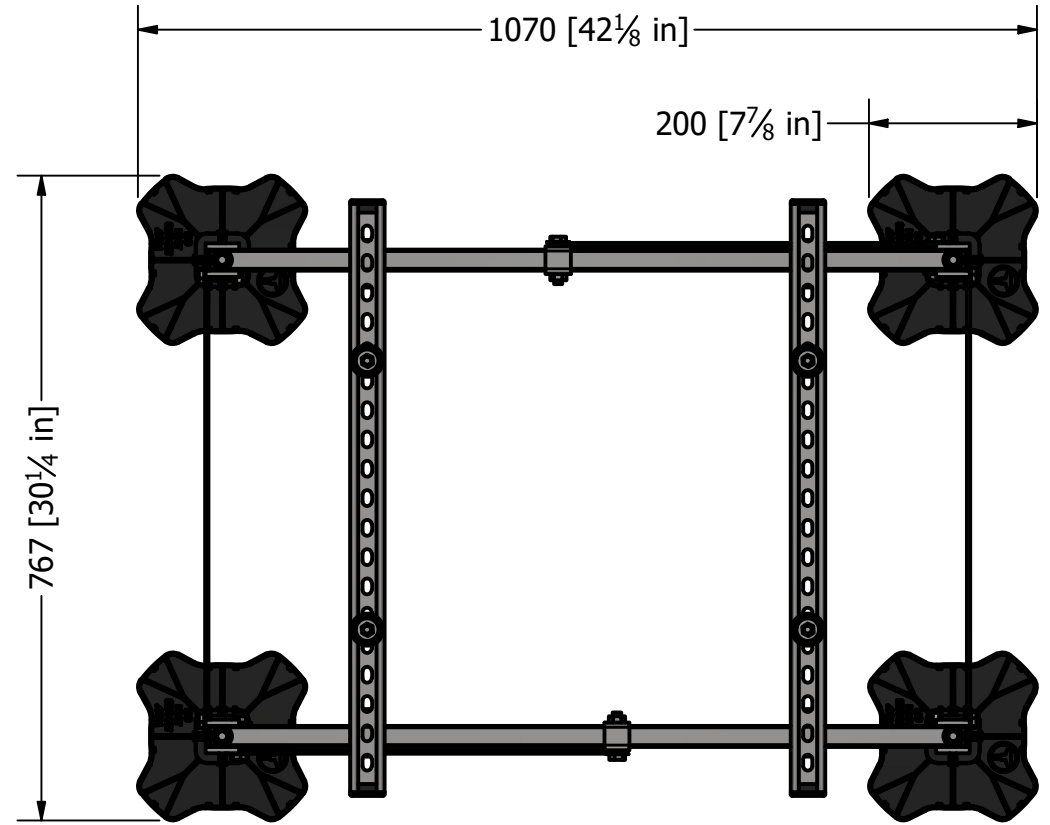
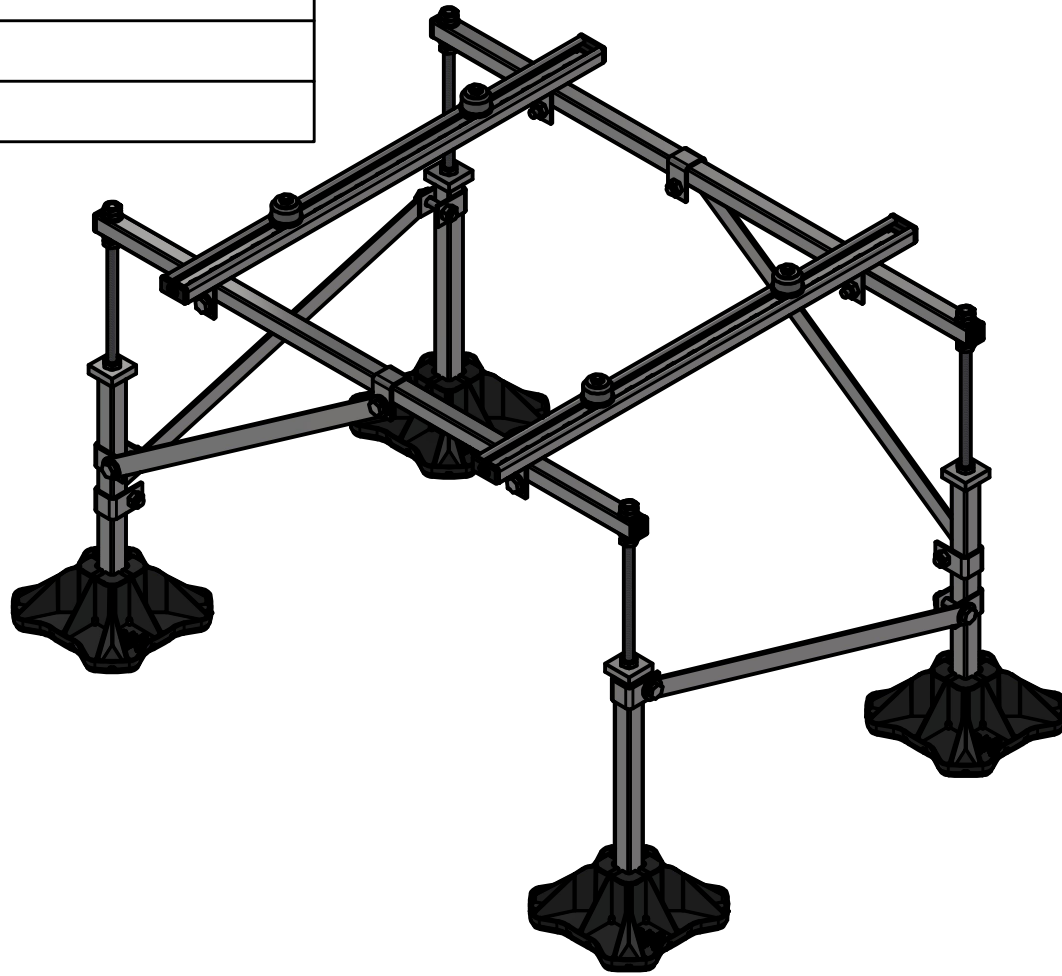

Installation and application considerations should include health, safety and environmental needs, regulations and standards, codes of practice, climate conditions, installation location, product orientation, evaluation of the roof structure, composition, surface and condition, ancillary and complimentary products and materials. Big Foot Systems recommend that all rooftop products are handled and installed by suitably qualified persons. All scheme designs are based on the use of Big Foot Systems' products and materials only. Terms and conditions available on request

REV A	DATE:	22/07/2023
	DRAWN:	E.OLUWAROUNKE
	CHECKED:	S.BIRCH

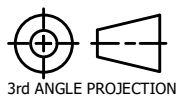

SCALE: 1 : 10
DIMENSIONS IN mm U.O.S
TOLERANCES: 0.0 ± 0.5mm U.O.S
SHEET 1 OF 2

A3

TITLE:
BN8100/1 - Mini Frame - Tall
 DWG No.
BN8100-1 + BN8101-1.dwg

THIS DRAWING IS COPYRIGHT AND THE PROPERTY OF BIG FOOT SYSTEMS LIMITED



PROJECT REF:	
UNIT REF:	
FOOT PRESSURE:	
UDL:	

Material grade: BS EN 10219-1:2006 (S235JR). Welding standard: BS EN ISO 15614-1: 2016. Galvanizing standard: BS EN ISO 1461:2009
 Reference specification document "Custom Fabrication Specification" (BF-SPEC-050411) for further information
 Reference specification document "Big Foot Systems Steel Specification (BF-SPEC-230610) for further information

PARTS LIST			
ITEM	QTY	PART NUMBER	DESCRIPTION
1	1	BN8100/1	MINI FRAME - TALL
2	1	BN8101/1	MINI EXTENDER - TALL

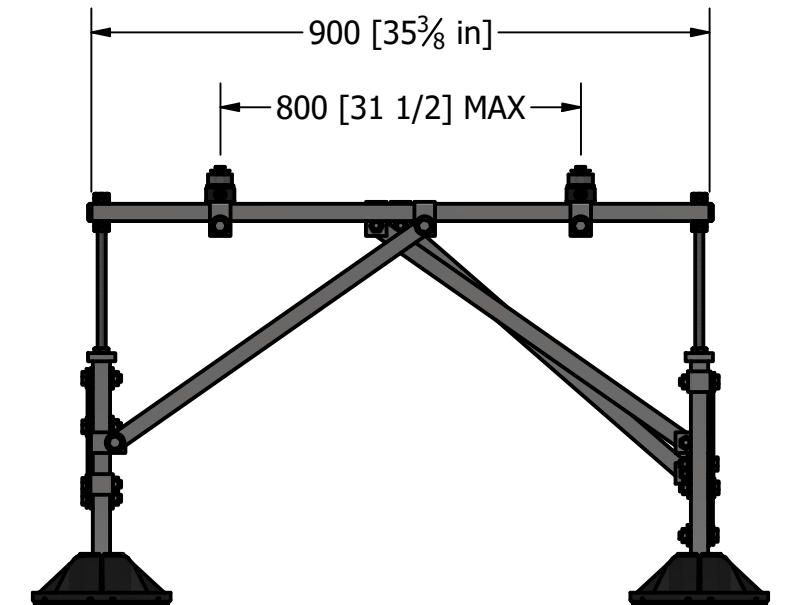
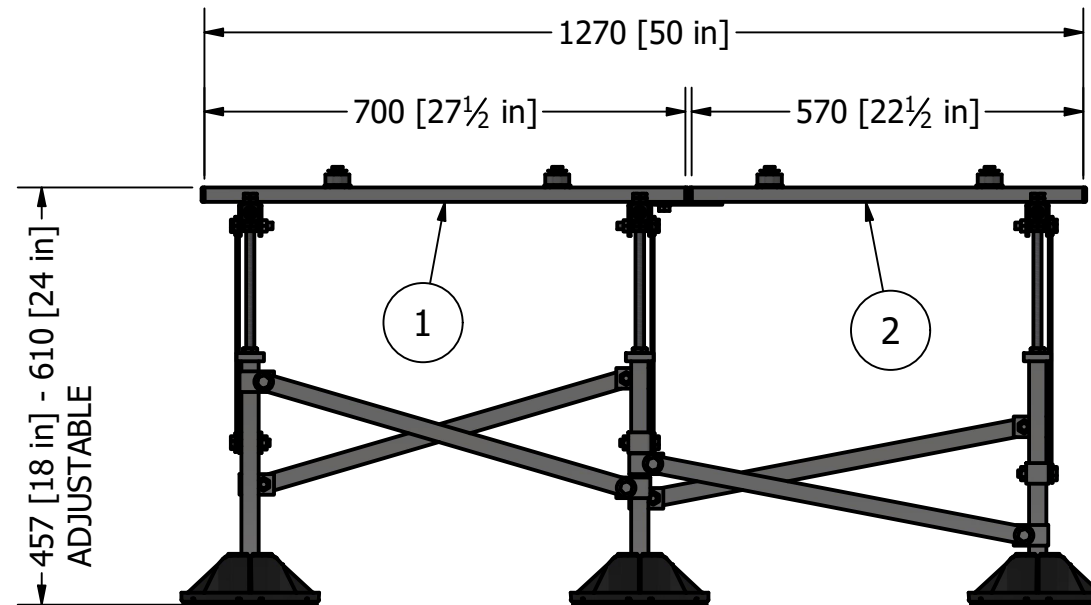
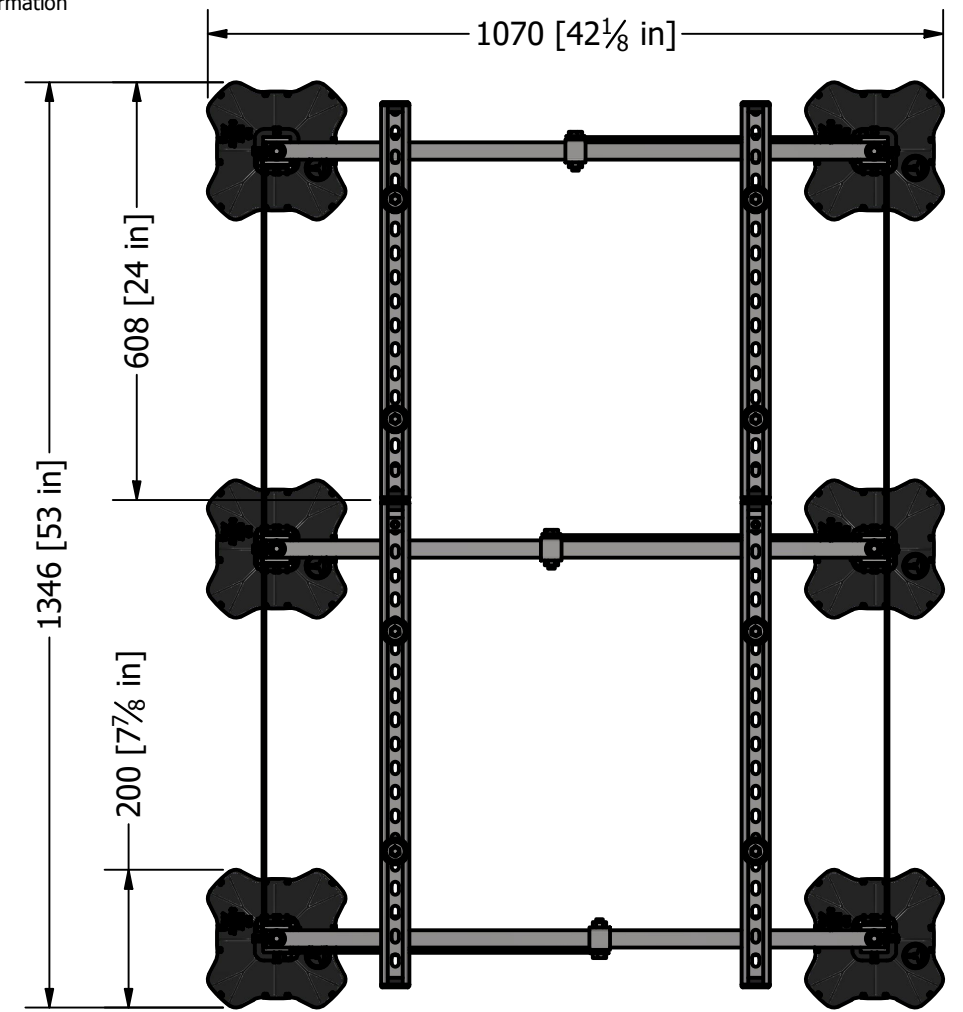
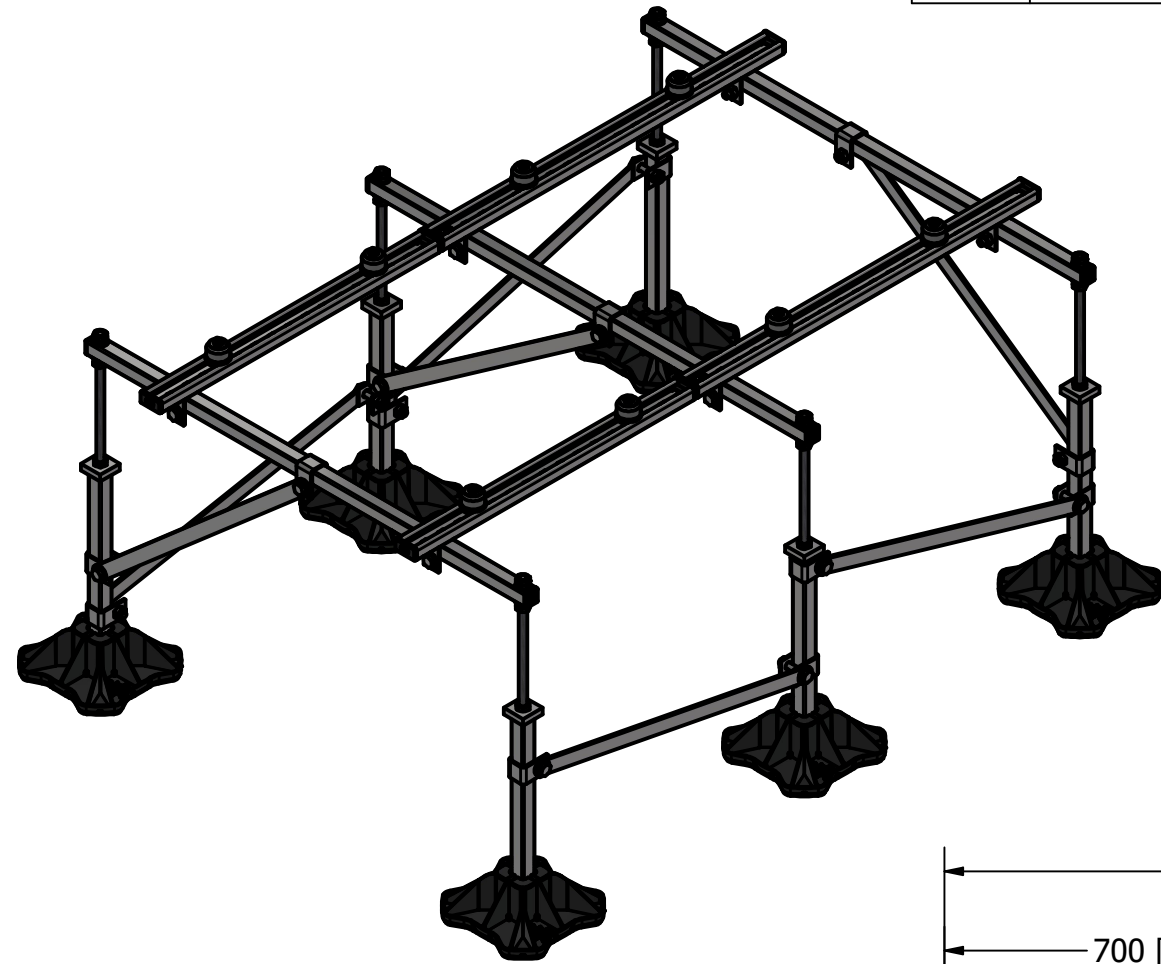

Installation and application considerations should include health, safety and environmental needs, regulations and standards, codes of practice, climate conditions, installation location, product orientation, evaluation of the roof structure, composition, surface and condition, ancillary and complimentary products and materials. Big Foot Systems recommend that all rooftop products are handled and installed by suitably qualified persons. All scheme designs are based on the use of Big Foot Systems' products and materials only. Terms and conditions available on request

REV A	DATE:	22/07/2023
	DRAWN:	E.OLUWAROUNKE
	CHECKED:	S.BIRCH

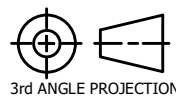

SCALE: 1 : 10
DIMENSIONS IN mm U.O.S
TOLERANCES: 0.0 ± 0.5mm U.O.S
SHEET 2 OF 2

A3

TITLE: BN8100/1 + BN8101/1 - MINI & EXT - TALL
DWG No. BN8100-1 + BN8101-1.dwg

THIS DRAWING IS COPYRIGHT AND THE PROPERTY OF BIG FOOT SYSTEMS LIMITED

