

Mini Blanc™

CONDENSATE REMOVAL PUMP

The Mini Blanc is all about neat finishes and easy installs. Stylish and powerful, it mounts directly beneath wall units making it ideal for retrofit installations where aesthetics matter. Backed by Aspen reliability and a 2-year warranty, it's a clean choice for clean lines. **If you're looking for state-of-the-art of pump technology, upgrade to our Silent+ range.**

20L/h max. flow

10m max. rec. head (flow rate 4L/h)

19dB(A) @ 1m

Key Features

- Fast install
- Easy maintenance access
- Removable reservoir
- Quiet operation
- Elegant and stylish casing
- 2 year warranty

Suitability

- Up to 26kW / 90,000Btu/h
- High wall split systems
- **Perfect for...** Domestic and commercial use – where easy maintenance is key

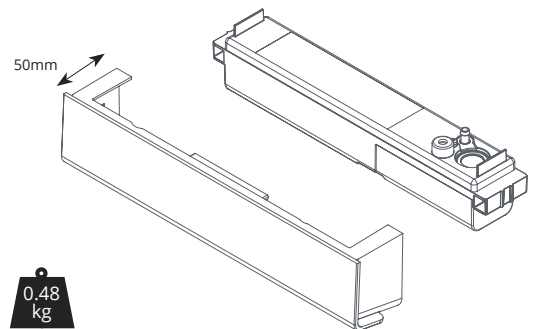
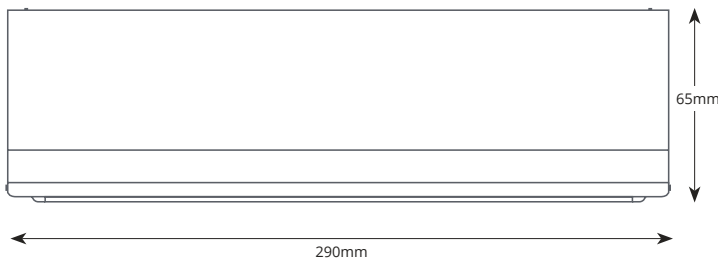

100V-250VAC @ 50Hz/60Hz	
Max. flow	20L/h @ 0m head
Max. rec. head	10m
dB(A) @ 1m	19dB(A)
Power supply	230 VAC, 50.60Hz, 0.16A / 5W
Rated	Continuous
Class	II
Max. unit output	26kW (90,000Btu/h)
Max. water temp	40°C (104°F)
Inlet/outlet	20mm in 6mm out
IP Protection	IP24
Safety switch	5A Normally closed
Self priming	✓

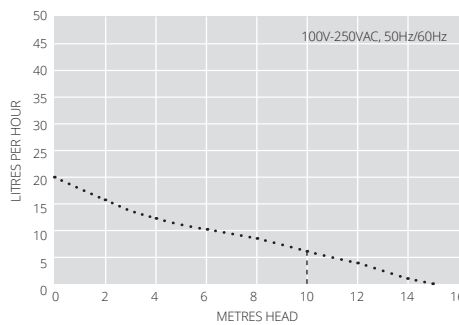

OPTIONS	
Mini Blanc	FP3578

IN THE BOX	
Mini Blanc pump, Hard wired 1.5m power cable	
• Fitting template (part of box) • Quick start guide	

SPARES		
Description		Part No.
Mini Blanc 4.5 Foam Filter Spares (x10)		FP3587
Barbed anti-siphon device		FP3336/1
Reservoir copper mesh filter (x10)		FP3460

Visit aspenpumps.com for more installation accessories.

Download full manual at aspenpumps.com